

SHANTUI

L58K-M

Wheel Loader



Emissions Certified	Stage V
Gross Power	170 kW (228 hp) @ 2200rpm
Operating Weight	18.700 kg
Bucket Size	3.0 m ³
Dump Clearance	3450 mm

VALUE THAT WORKS

L58K-M TECHNICAL PARAMETERS

ENGINE

Emission Regulation	Euro V
Make	Weichai
Model	WP10HG230E670
Rated Power	170kW /2200rpm
Max Torque	1150Nm
Displacement	9.5 L
Number of Cylinders	6
Aspiration	Turbocharged

LOADERARM PERFORMANCE

Tipping Load - Full Turn	5500 kg
Bucket Breakout Force	≥185 kN
Maximum Dump Angle at Full Height	45°
Dump Clearance at Full Height Discharge	3450 mm
Dump Reach at Full Height Discharge	1160 mm
Maximum Hinge Pin Height	4500 mm
Maximum Digging Depth, Bucket Level	110 mm
Bucket Capacity	3.0 m ³
Operating Weight	18700 kg

TRANSMISSION

Transmission Type	Electric control gearbox
Torque Converter	Single-stage 3-element
Maximum Travel Speed, fwd	35 km/h
Maximum Travel Speed, rev	25 km/h
Number of Speeds, fwd	4
Number of Speeds, rev	3

AXLES

Type	Wet
Differential Type	Conventional
Axle Oscillation	±12°

STEERING

Steering Configuration	Articulated
Steering System Pressure	16 Mpa

BRAKES

Service Brake Type	Wet braking
Service Brake Actuation	Full hydraulic braking
Parking Brake Type	Manual electronic control
Parking Brake Actuation	Electro-hydraulic release

TIRES

Tire Size	23.5-25
-----------	---------

HYDRAULIC SYSTEM

Main Pump Type	Pump
Main Relief Pressure	18 Mpa
Raise time	5.1 S
Total Cycle Time	10.2 S

SERVICE CAPACITY

Fuel Tank	300 L
Hydraulic oil Tank	170 L
Engine Oil	21 L
Axles, each	Front axle 39L/ Rear axle 30L
Transmission	27 L
Antifreeze	55 kg

DIMENSIONS

Length	8730 mm
Width	3066 mm
Height	3450 mm
Wheelbase	3300 mm
Wheel Tread	2250 mm
Ground Clearance	430 mm
Turn Angle, Either Side	35°
Turning Radius, Outside of Tire	6682 mm
Turning Radius, Center of Tire	6385 mm
Turning Radius, Bucket Carry	6685 mm

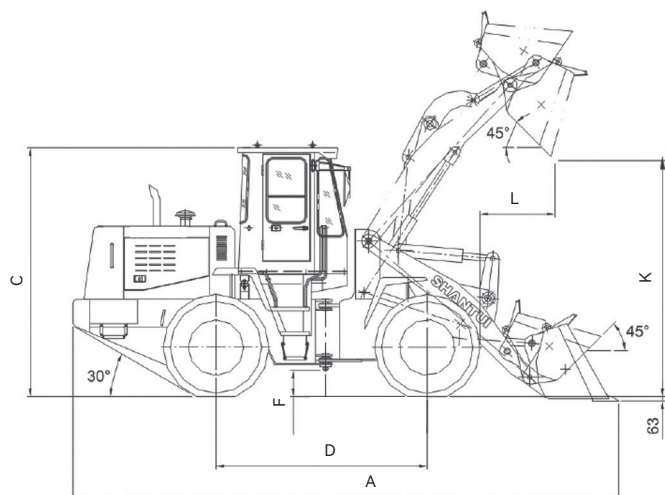
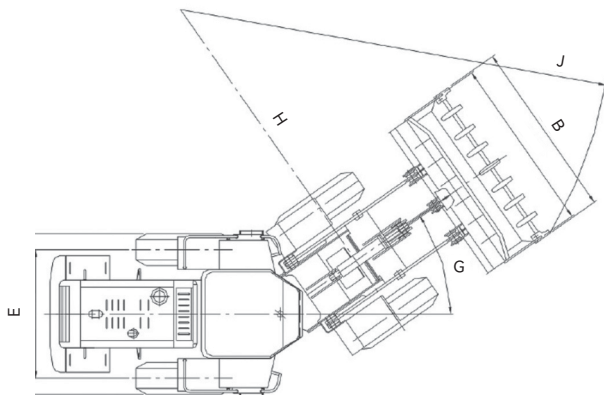

* THESE SPECIFICATIONS ARE SUBJECT TO CHANGE WITHOUT NOTICE. THE PICTURES MAY INCLUDE OPTIONAL CONFIGURATION. THE ACTUAL COLOR & APPEARANCE OF THE PRODUCT MAY DIFFER FROM WHAT IS SHOWN.



Shantui Social

SHANTUI CONSTRUCTION MACHINERY CO., LTD.
 ADD: NO. 58, G327 HIGHWAY, HI-TECH ZONE, JINING CITY, SHANDONG, CHINA
 TEL: +86-537-2909369 FAX: +86-537-2311219
 EMAIL: trade@shantui.com WEB: www.shantui.com

SHANTUI
 VALUE THAT WORKS