

SHANTUI

Member of **SDHI** Group

SE20

Mini Crawler Excavator



Emissions Certified	Stage V
Gross Power	11.8 kW (16 hp) @ 2300 rpm
Operating Weight	2 000 kg
Bucket Size	0.04 m ³
Max. Digging Depth	2420 mm

VALUE THAT WORKS

TECHNICAL PARAMETERS SE20

ENGINE

Model	Kubota D902
Type	Water-cooled
No. of cylinders	3
Emission standard	Tier 4 Final / Stage V
Displacement	1.0 L
Rated power	11.8 kW(16hp)/ 2300rpm

HYDRAULIC SYSTEM

Type	Variable plunger pump
Max. flow	64.4 L/min

DIGGING FORCE (ISO6015)

Bucket digging force	16 kN
Arm digging force	9.5 kN

BUCKET

Type	Standard digging bucket
Bucket capacity	0.04 m ³
Bucket width	450 mm

TRAVEL SYSTEM

Travel motor	SHANTUI
No. of track rollers	3x2
No. of carrier rollers	n/a
Track type/ track shoe width	Rubber / 230 mm (optional steel track)
Travel speed	2.4/4.2 km/h
Traction force	18 kN
Gradeability	58°

SWING SYSTEM

Swing speed	0 ~ 10 r/min
Brake type	n/a

FLUIDS AND LUBRICANTS (L)

Fuel tank	23
Cooling system	5
Engine oil	3.7
Hydraulic oil tank / system capacity	17/25

OPERATING WEIGHT AND GROUND PRESSURE

Operating weight	2000 kg
Ground pressure	30 kPa

OPERATING RANGE (mm) Boom: 1828

	Arm: 950	Arm: 1100
A. Max. digging height	3535	3610
B. Max. dumping height	2448	2525
C. Max. digging depth	2270	2420
D. Max. vertical digging depth	1910	2050
E. Digging distance	3925	4050
F. Dig radius (ground level)	3860	3990
G. Overall length	3845	
H. Ground contact length (transportation)	2460	
I. Overall height (to top of a boom)	1105	
J. Overall width	990 / 1300	
K. Overall height (to top of roof)	2400	
L. Counter weight ground clearance	460	
M. Ground clearance	145	
N. Tail swing radius	1070	
O. Track length	1593	
P. Track gauge	760/1070	
Q. Track width	990/1300	
R. Dozer height	230	
S. Dozer dig depth	235	

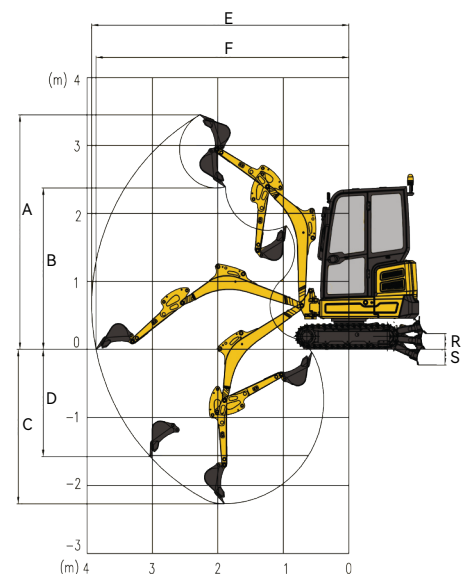
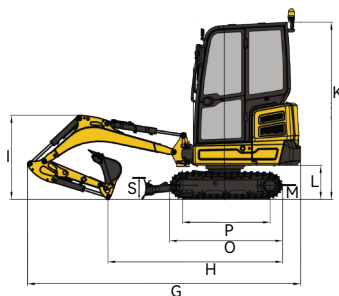
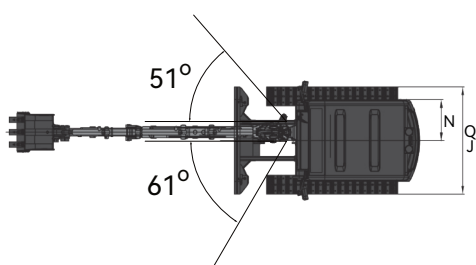

* THE SPECIFICATIONS ARE SUBJECT TO CHANGE WITHOUT NOTICE.
THE PICTURES MAY INCLUDE OPTIONAL CONFIGURATION; THE ACTUAL COLOR AND APPEARANCE OF THE PRODUCT MAY DIFFER FROM WHAT IS SHOWN



SHANTUI BELGIUM (EUROPE) SRL

Mondeolaan 1/A
3600 Genk
BELGIUM

mail: europe@shantui.com
phone: +32 89 358 430
www.shantui-eu.com

Contact us!

SHANTUI

Member of SDHi Group